

Interfacing Analog and Digital Worlds: Conversion Principles and Circuits



Nimal Skandhakumar

Faculty of Technology
University of Sri Jayewardenepura

2019

From Analog to Digital to Analog

Mixed signal systems basically consist of DSP, ADC, DAC, and pre/post filters. The signals are converted between continuous time and discrete time.

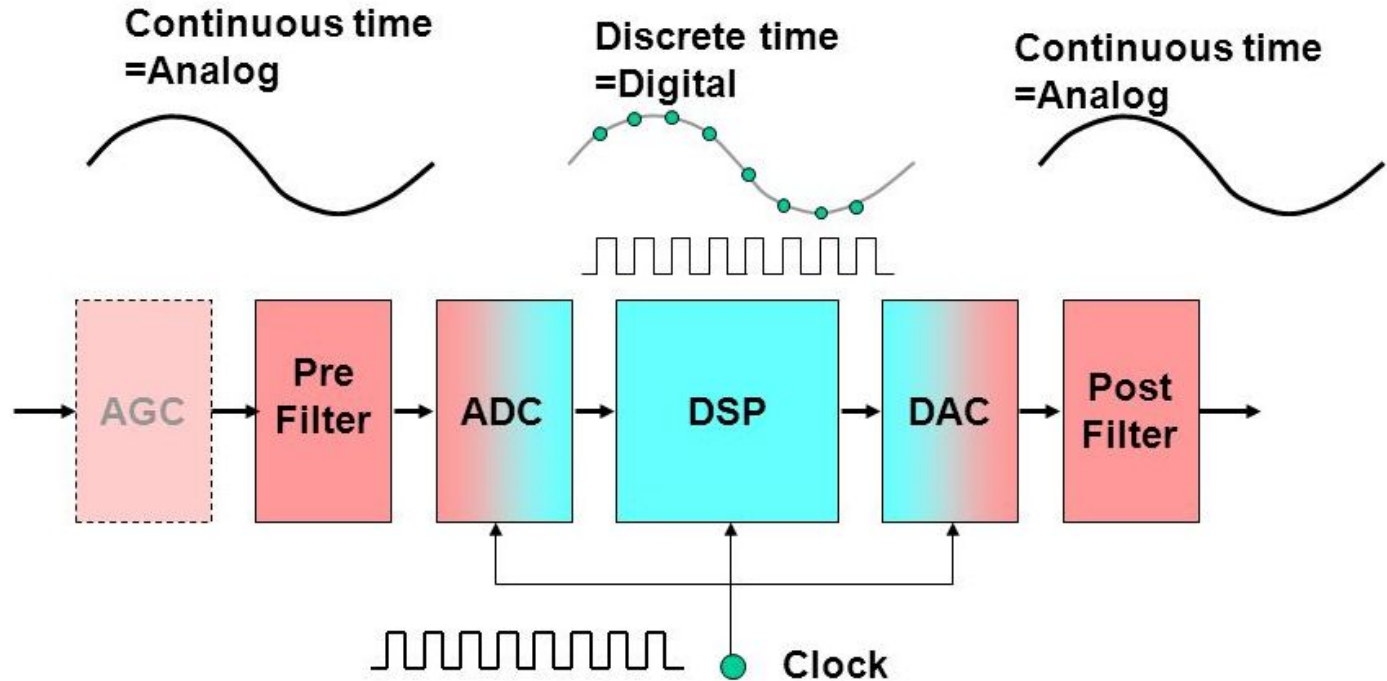

Analog Signal

- A continuous signal that contains time-varying quantities, such as temperature or speed, with infinite possible values in between
- Can be used to measure changes in some physical phenomena, such as light, sound, pressure, or temperature.

1. Continuous
2. Infinite range of values
3. More exact values, but more difficult to work with

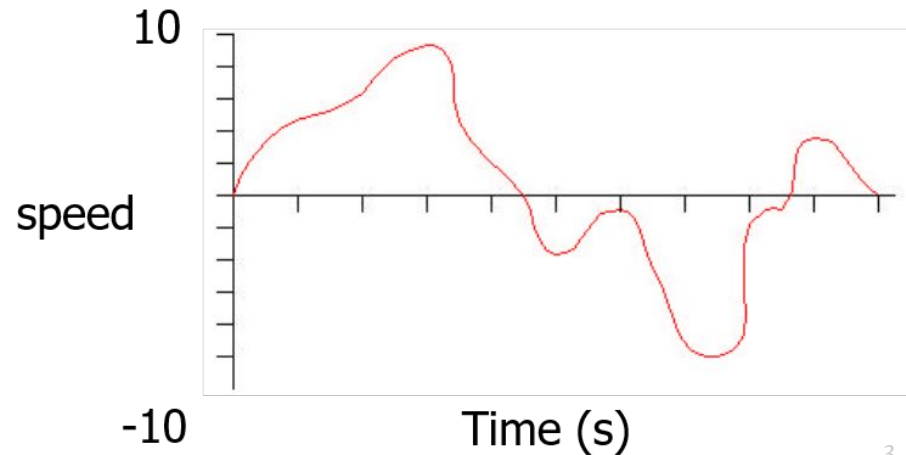

Analog Signal

- Advantages:
 1. Major advantages of the analog signal is infinite amount of data.
 2. Density is much higher.
 3. Easy processing.
- Disadvantages:
 1. Unwanted noise in recording.
 2. If we transmit data at long distance then unwanted disturbance is there.
 3. Generation loss is also a big con of analog signals.

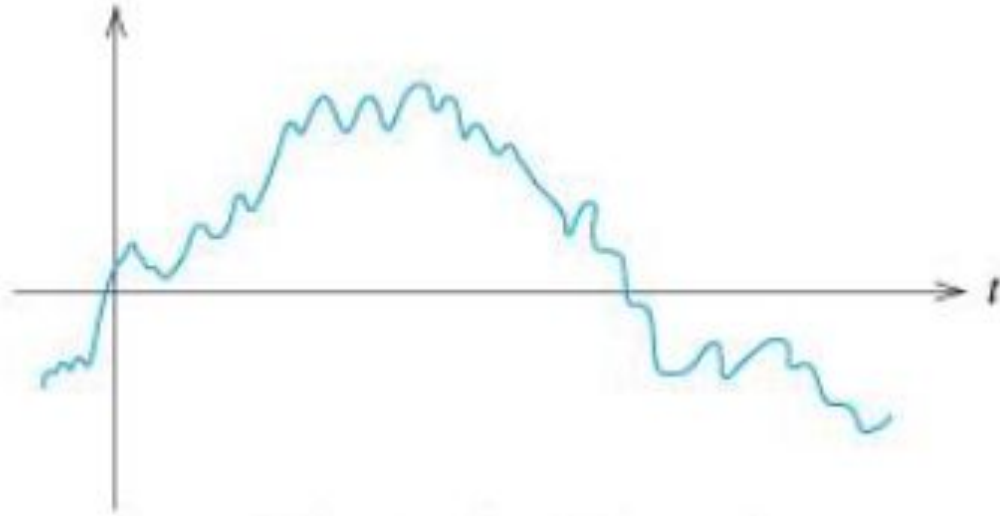

Digital Signal

- A type of signal that can take on a set of discrete values (a quantized signal)
- Can represent a discrete set of values using any discrete set of waveforms; and we can represent it like (0 or 1), (on or off)

1. Discrete
2. Finite range of values
3. Not as exact as analog, but easier to work with

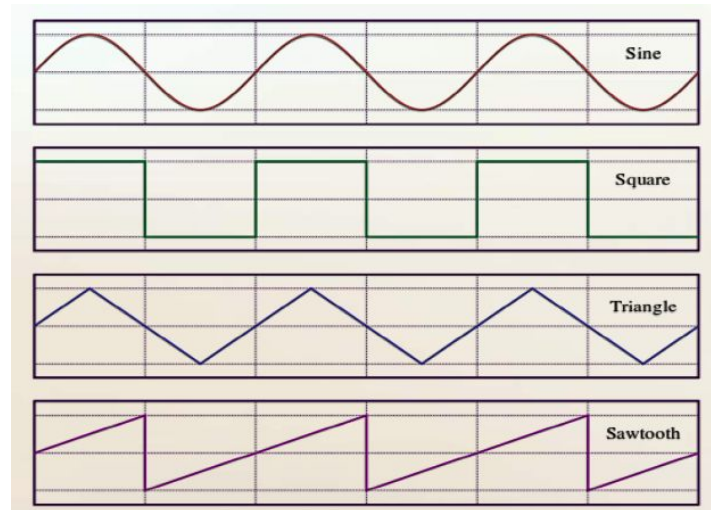

Difference between analog and digital signals

	Analog	Digital
Signalling	Continuous signal	Discrete time signal
Data transmissions	Subjected to deterioration by noise during transmission and write/read cycle.	Can be noise-immune without deterioration during transmission and write/read cycle.
Bandwidth	Analog signal processing can be done in real time and consumes less bandwidth.	There is no guarantee that digital signal processing can be done in real time and consumes more bandwidth to carry out the same information.
Power	High power consumption	Normally draws only negligible power
Errors	Analog instruments usually have a scale which is cramped at lower end and give considerable observational errors.	Digital instruments are free from observational errors like parallax and approximation errors.
Example	Human voice in air, audio and video transmission.	Computers, CDs, DVDs, and other digital electronic devices.

Analog-to-Digital Conversion (ADC)

- Sampling:
 - Taking amplitude values of the continuous analog signal at discrete time intervals
- Quantization:
 - Assigning a numerical value to each sampled amplitude value
- Coding:
 - Once the amplitude values have been quantized they are encoded into binary using an Encoder.

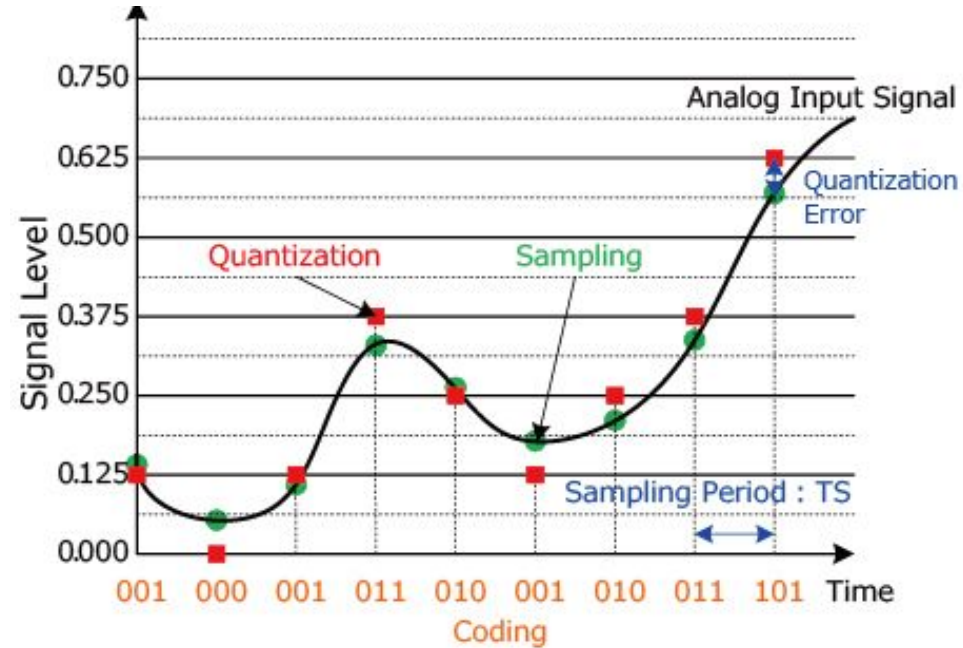

Sampling

- The process of taking a sufficient number of discrete values at point on a waveform that will define the shape of waveform.
- It converts analog signal into series of impulses, each representing amplitude of the signal at given point.
- The more samples you take, the more accurately you will define the waveform.
- **Sampling Period $T_s = 1/F_s$ Sampling Frequency**

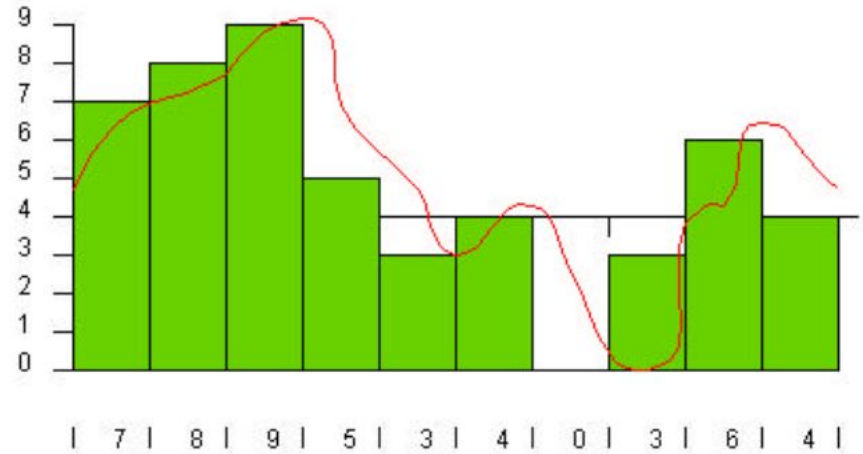

Quantizing

- Assigning a numerical value to each sampled amplitude value
 - from a range of possible values covering the entire amplitude range
- N – number of possible states that the converter can output is
- n – number of bits in the AD converter
- Possible states:
 - $N = 2^n$
- Analog quantization size:
 - $Q = (V_{max} - V_{min}) / N$

Quantizing – Example

- Discrete states for
 - a 3 bit A/D converter
 - 0-10V signals
- Solution:
 - $N = 2^n = 8$
 - $Q = (10V - 0V) / 8 = 1.25V$

Output States	Discrete Voltage Ranges (V)
0	0.00-1.25
1	1.25-2.50
2	2.50-3.75
3	3.75-5.00
4	5.00-6.25
5	6.25-7.50
6	7.50-8.75
7	8.75-10.0

Encoding

- Assign the digital value (binary number) to each output state

Output States	Output Binary Equivalent
0	000
1	001
2	010
3	011
4	100
5	101
6	110
7	111

Types of A/D convertor

- Flash ADC
- Digital-Ramp/Dual slope/Counter slope ADC
- Successive Approximation ADC

Flash ADC*

- Consists of a series of comparators
- Each one comparing the input signal to a unique reference voltage
- Comparator outputs connect to the inputs of a priority encoder circuit
- Encoder produces a binary output

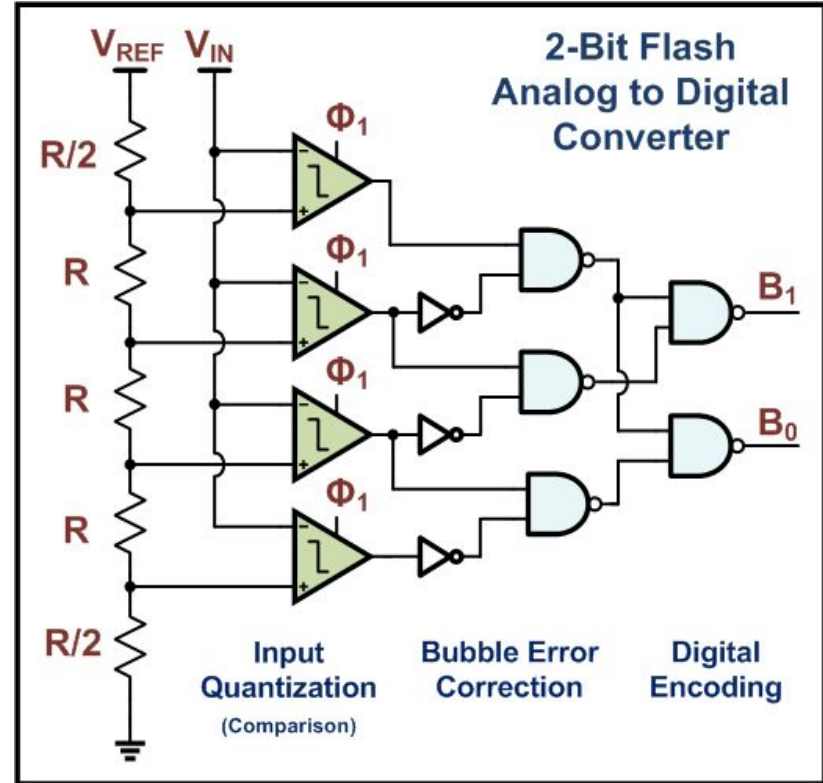

Issues in A to D conversion – Aliasing

- If we sample at a low rate then there is a possibility of reconstructing the wrong waveform.
- The theory is that sampling must be at 2 times the signal frequency or else frequency components above this will be lost.
 - Nyquist frequency = $2 \times F_{\max}$
- Rule of thumb for better results at least $10 \times F_{\max}$ is required.

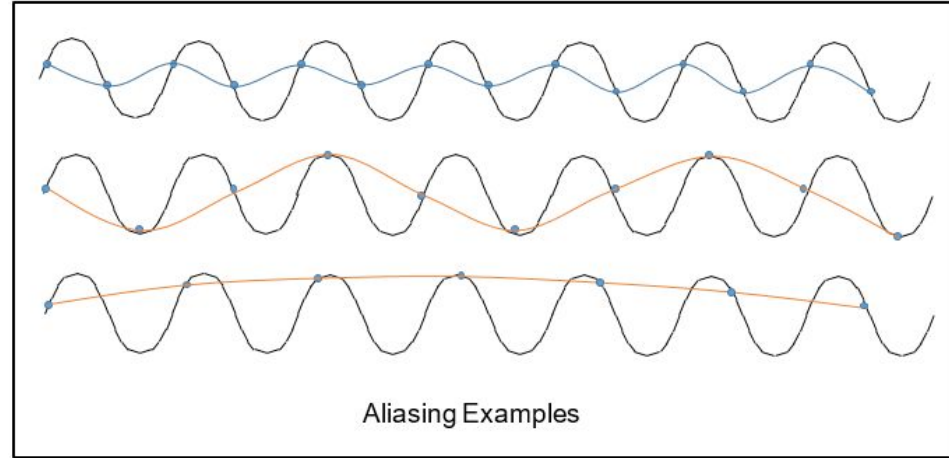

Issues in A to D conversion – Data Size

- Audio signal for music has a complex rapidly changing waveform.
 - Sampling rate: 44,100 times per second
 - Resolution: 16 bits – gives the height as 1 in 65,536 possible values
 - Data per second: $44100 \times 16 = 705600$ bits = 88200 bytes
 - Data for 1 minute music: $60 \times 88200 = 5292000$ B = 5.047 MB
- Many other data recorded do not change as rapidly as audio, and so require much lower sampling rates and resolution.
 - E.g. wind speed does not change anywhere near as fast as audio signals – 0.5sec and resolution

Digital-to-Analog Conversion (DAC)

- From signals having a two defined levels or states (binary)
- To signals having a theoretically infinite number of states (current, voltage, or electric charge).
- Basically, digital-to-analog conversion is the opposite of analog-to-digital conversion.

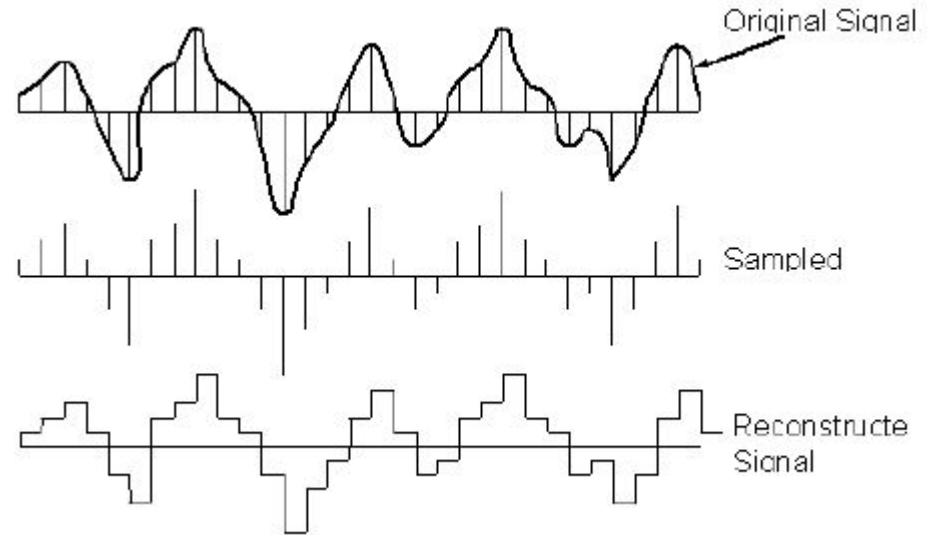

Digital-to-Analog Conversion (DAC)

- Decoder Method
 - A decoder is a method that converts a digital signal and then passes it on to another circuit.
- Binary Method
 - A circuit that receives and processes unconverted digital signals is referred to as a binary system.

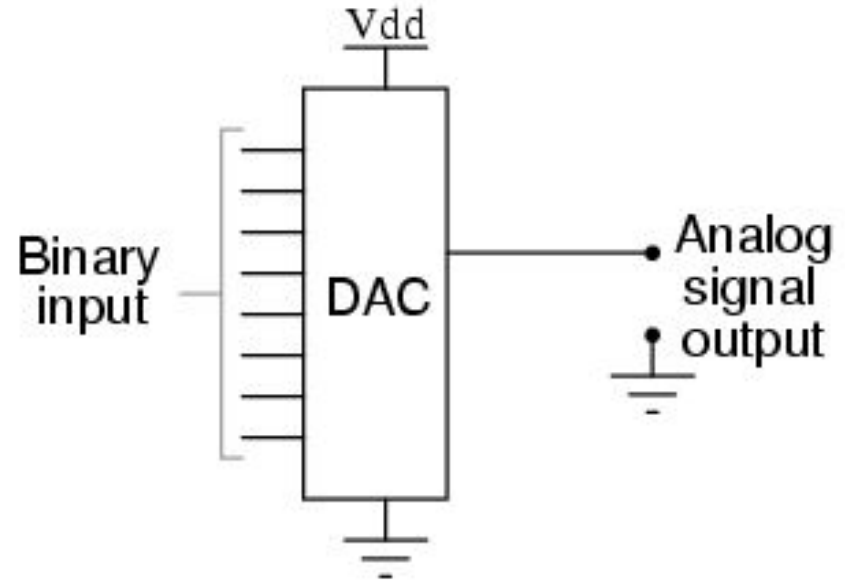

Resistance Voltage Divider Type DAC (Decoder)

- In the 3bit (resolution) DAC, voltage is divided via resistors and selected at one node using switches.
 - Advantage: superior linearity and, in principle, guaranteed monotonicity.
 - Disadvantage: exponentially increased circuit scale depending on the resolution
 - 8 resistors and a switch are needed for 3bit operation, 16 resistors and a switch for 4bit, 1024 resistors and a switch for 10bit, etc.

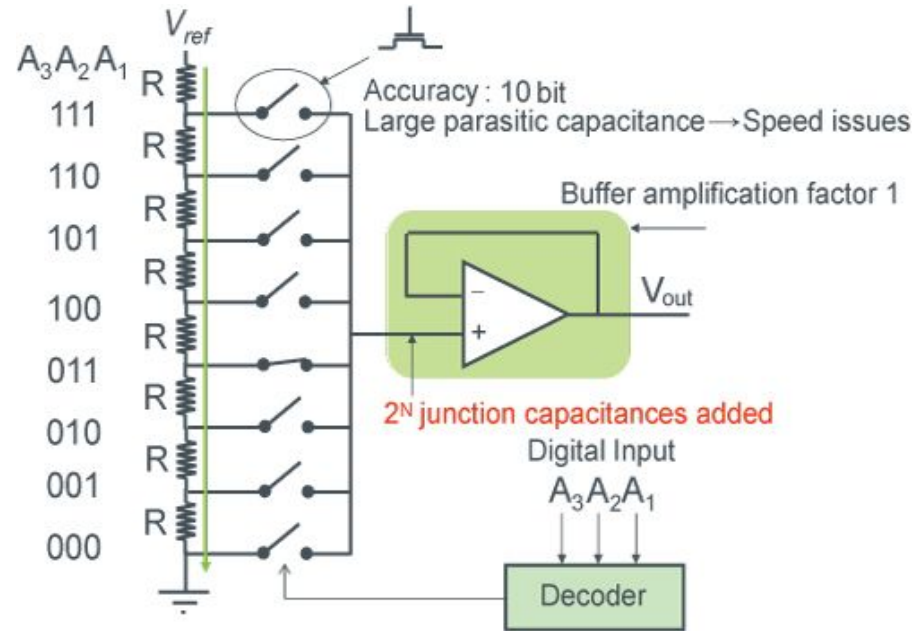

R-2R ladder DAC (Binary, using resistors)

- An R-2R D/A converter with 4bit resolution.
- This enables the creation of smaller D/A converters with up to 10 bit resolution
 - required resistors include $3N$ for N bit D/A converter
 - neither a decoder nor large switches are needed
 - when combined with other methods resolutions up to 14bits are possible
- <https://www.youtube.com/watch?v=bXUfDLF4MVC>

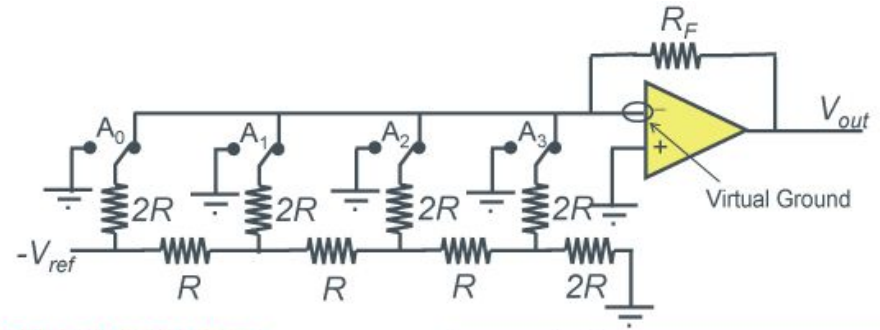

Switch → Partial Resistance

Switch dimensions are made to be proportional to the amount of current

MOSFET $\left(\frac{W}{L}\right)$ is made proportional to the current

$$V_{out} = R_F \left(I_r \cdot A_0 + \frac{I_r}{2} \cdot A_1 + \frac{I_r}{2^2} \cdot A_2 + \frac{I_r}{2^3} \cdot A_3 \right)$$

$$I_r = \frac{V_{ref}}{2R}$$

Signal transformation life cycle

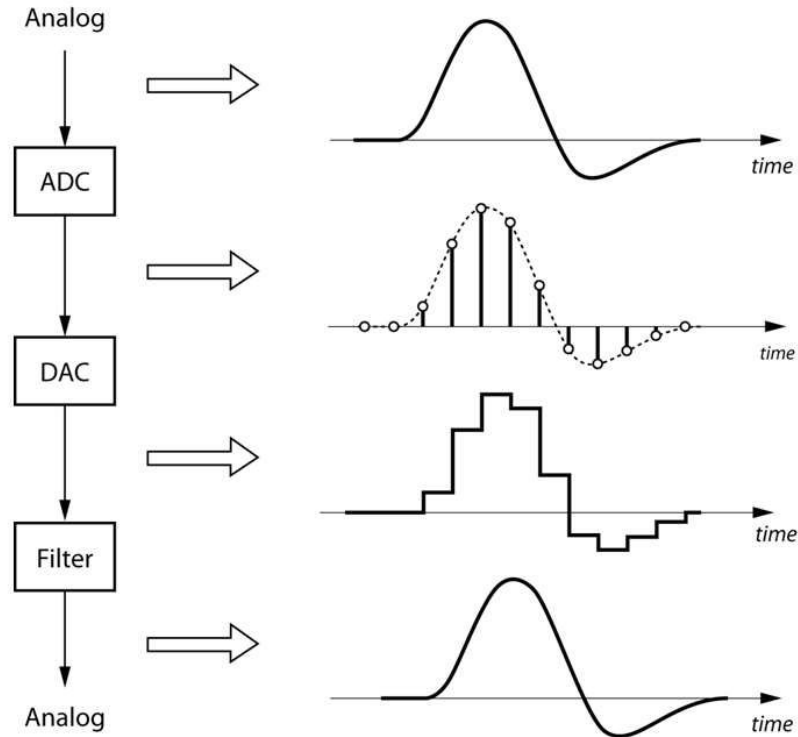

Project Design...